

ANTS MVB AM01S Series

The AM01M Series is a PC/104 type interface product that conforms to international standards IEC 61375-3-1 MVB.

This product supports a physical transmission media called ESD(Electrical Short Distance) and uses its own developed control technology. This product is applicable to the MVB system through the Logic Bombardier TCMS level 1 MVB Conformance Test and physical layer.

- Possible to operate with a simple setting and designed for making it easy for the user to know MVB Line status and Frame information.
- You can use Process Data, Message Data, Device Status, Bus Manager through the Function options.
- It is designed for the railway industry and can operate in harsh environments.
- Suitable for humidity through coating of 30~60 μ m.
- Improved EMI and vibration robustness.
- Operating temperature is -40 to +85 $^{\circ}$ C.

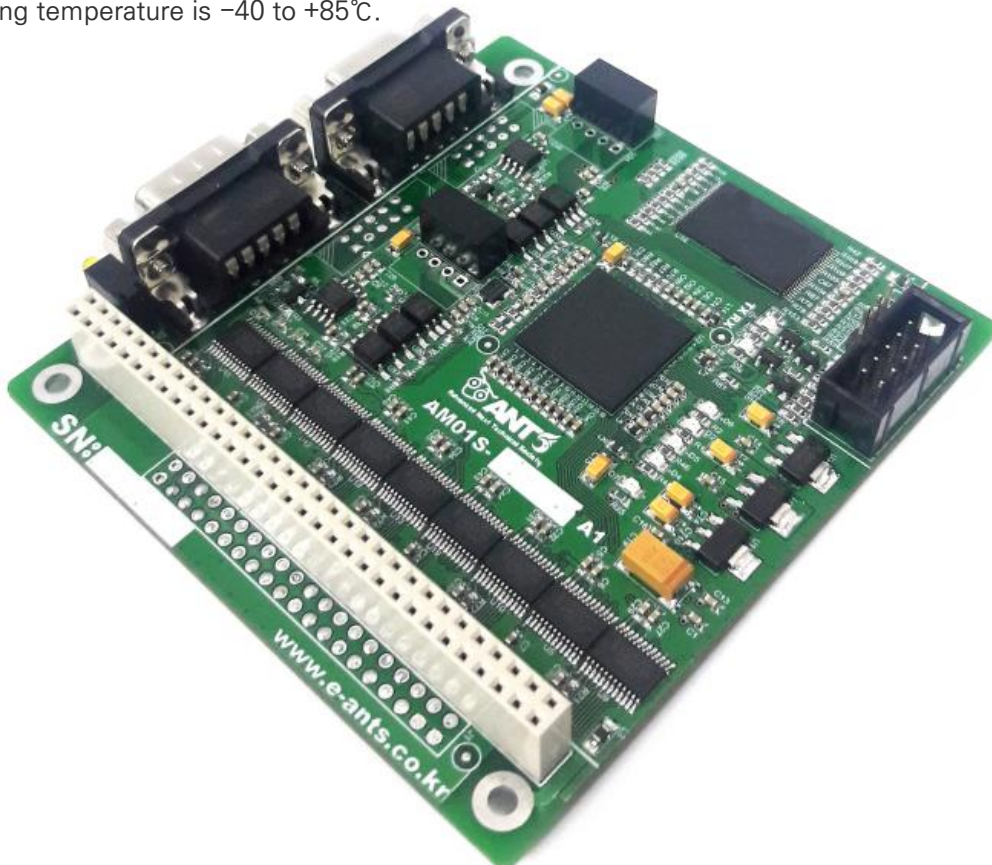

ANTS Co., Ltd.

1164-21, Haeun-daero, Haeundae-gu, Busan, 48069, Republic of Korea

Tel. +82-51-742-1324 | Fax. +82-51-701-1324 | Mail. staff.ants@gmail.com

This product specification is also available in PDF format at www.e-ants.co.kr



AM01S Series

Data sheet Preamble

1. Customer Rights

As you purchase the product described in this Data Sheet, the purchaser has the right to use it based on the specified purpose and operation of the product, service and maintenance instructions of the product. However, ANTS has other rights including intangible assets.

2. Product Validity

The properties of the product are described in the Data Sheet and are valid until the warranty period on the basis of the order date.

3. Customer Obligations

Buyers must verify that the product is suitable for their purchase intent. Designing systems and applications within supply coverage of ANTS is guaranteed in normal operation, but if the system is configured with other products, malfunctions may occur and be required corresponding action.

4. Quality Assurance

The product warranty is according to ANTS discretion and is subject to repair or replacement at the ANTS factory. The warranty covers of the products that are stocked due to defects in spite of the proper handling. Does not warrant the defects and loss caused by negligence or misuse against property of the products presented by ANTS. The warranty period of the product is 36 months and managed as a serial number from the date of shipment. The warranty does not cover products with defects and warranties due to connection with other products.

5. Other

You must bear the cost of any indirect loss incurred due to non-delivery of the product or warranty. Basically, it is not possible to cancel after order, and the cost of the loss should be defrayed by the buyer.

ANTS Co., Ltd.

1164-21, Haeun-daero, Haeundae-gu, Busan, 48069, Republic of Korea

Tel. +82-51-742-1324 | Fax. +82-51-701-1324 | Mail. staff.ants@gmail.com

www.e-ants.co.kr

1. Introduction	03
2. Block Diagram	
2-1. Hardware Structure	04
2-2. Logic Structure	06
3. MVB Interface	
3-1. Pin Assignment for the ESD Connector	07
3-2. MVB Connector Option	08
4. PC/104 Interface	
4-1. Pin Assignment for the PC/104 Connector	09
4-2. PC/104 Connector Option	10
5. Debug Serial Interface	11
6. Mechanical Data	
6-1. Component Layout	12
6-2. Dimensional Data	12
7. Technical Note	
7-1. State LED	14
7-2. PC/104 Timing Diagram	14
7-3. Power Up and Reset Sequence	14
8. Standard and Certification	
8-1. IEC 61375-3-1, IEC 61375-3-2 Standard Reference	15
8-2. PC/104 Specification Reference	15
8-3. Environment Test Standard Reference	15
8-4. MVB Conformance Test	16
9. Ordering Information	17

AM01S Series

1. Introduction

The AM01S series was developed for the control of railway vehicle MVB systems and has been verified in real vehicles through numerous projects and work at home and abroad.

It has been verified as functional conformity through IEC 61375-3-2 IEC Standard for Train Communication network and Part 3-2: MVB(multifunction vehicle bus) conformance testing according to TCN standard IEC 61375-3-1. Logic used in this product has been verified by Bombardier TCMS level 1 MVB conformance test.

The AM01S Series is designed to make it easy to set ESD MVB through PC/104 standard interface and checking to easy user's information such as MVB Line status and Frame information.

Process Data, Message Data, Device Status, Bus manager functions can be selected and used according to the user's application according to the Mount Option.

To meet railway environmental conditions, it consists of industrial devices with a working range of -40 to +85°C. Suitable to humidity through 30 to 60 μ m coatings and robust against EMI design and vibration.

SUPPORT

- You can get new products, latest data sheets and program source materials by visiting our website.
- Supports meetings and demonstrations from sales person if you place large orders.
- You can easily purchase demo or development boards from the online marketplace.
- This product specification is also available in PDF format at www.e-ants.co.kr

2. Block Diagram

2-1. Hardware Structure

It is representative model of AM01S Series equipped with Dsub and PC/104.

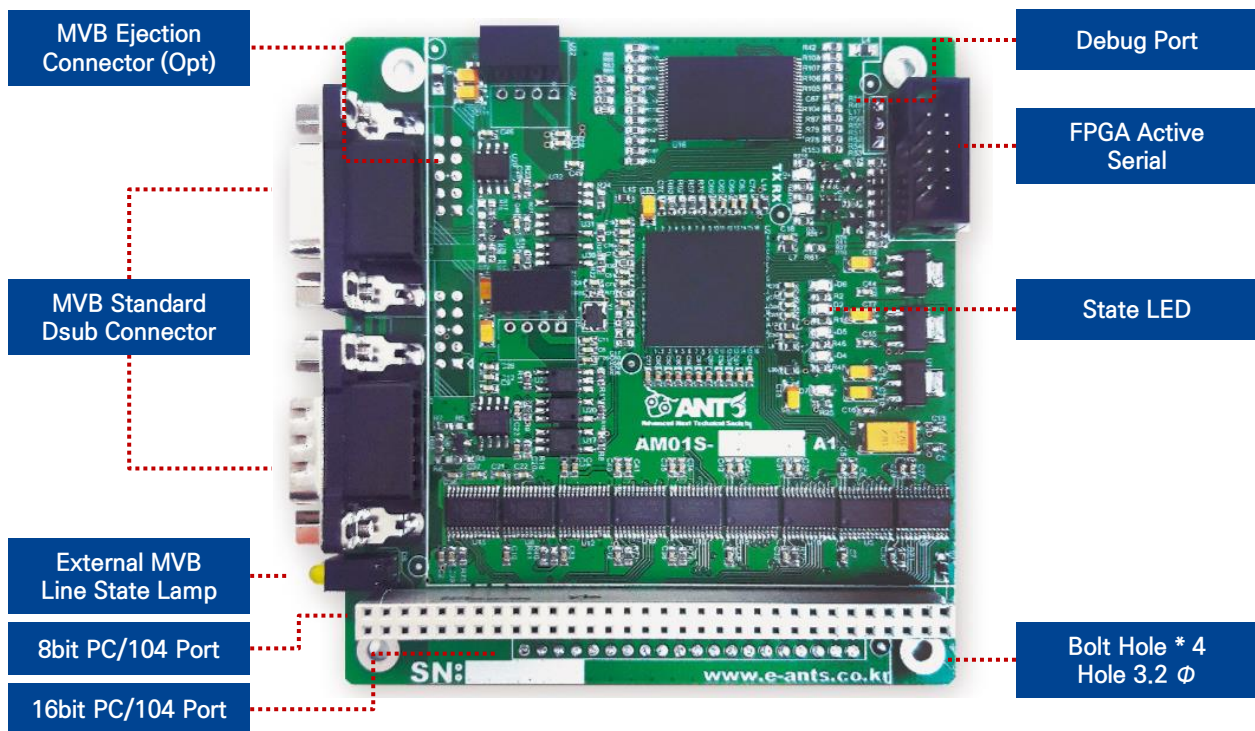

〈Figure 1-1. Hardware Image〉

Item	Spec
FPGA	Up to 16K Logic / Up to 54 Kb Memory / Embedded Flash
Traffic Memory	1M * 16bit SRAM, 10ns Speed
MVB Interface	ESD – DC & DC Isolation
MVB Function	Class 1, 2, 3 (Optional 4)
MVB Connector	Dsub 9pin Male/Female or 2.54mm Header 10pin
Host Interface	PC/104, SRAM Communication
Dimension	90 * 96 * 25mm, PC/104 Form factor
Operation Temperature	-40 ~ +85℃
Power	5VDC ±0.25V, 5V

〈Figure 1-2. Hardware Spec〉

AM01S Series

2. Block Diagram

2-1. Hardware Structure

This Figure is basic hardware configuration diagram of the AM01S Series.

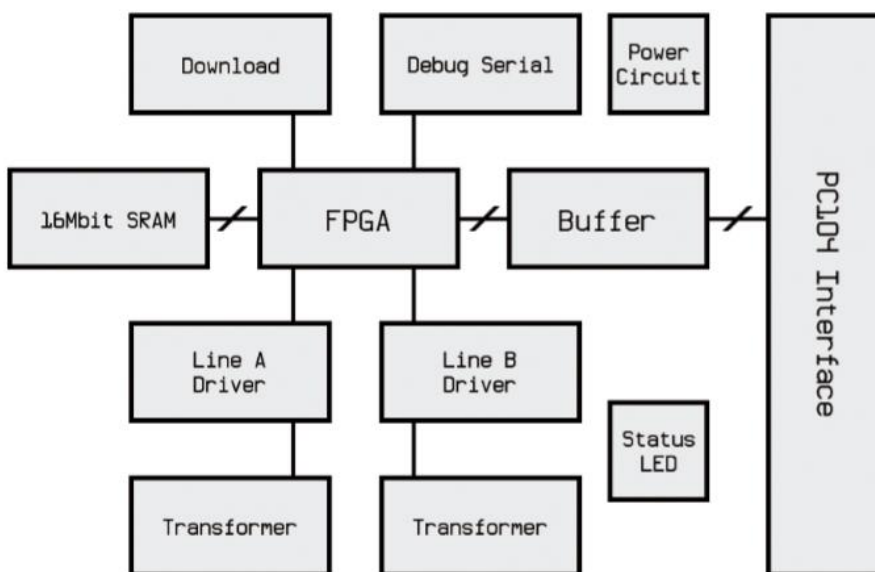

<Figure 1-3. Hardware Structure>

Item	Spec
MVB Controller	MVB Interface and Traffic Memory management
PC/104 Interface	Host System and Data Communication Interface, depending on the operating Mode, connect the input and output signals
Traffic Memory	Memory that shares Data transmitted and received by MVB and Data transmitted and received by PC/104
MVB Interface	MVB driver and transformer, ESD interface supported by transformer isolation
Debug Serial	Frame Counter status information of Master and Slave can be checked with 3.3V Serial
State Lamp	MVB Line status and internal Board status can be checked

<Figure 1-4. Hardware Spec>

2. Block Diagram

2-2. Logic Structure

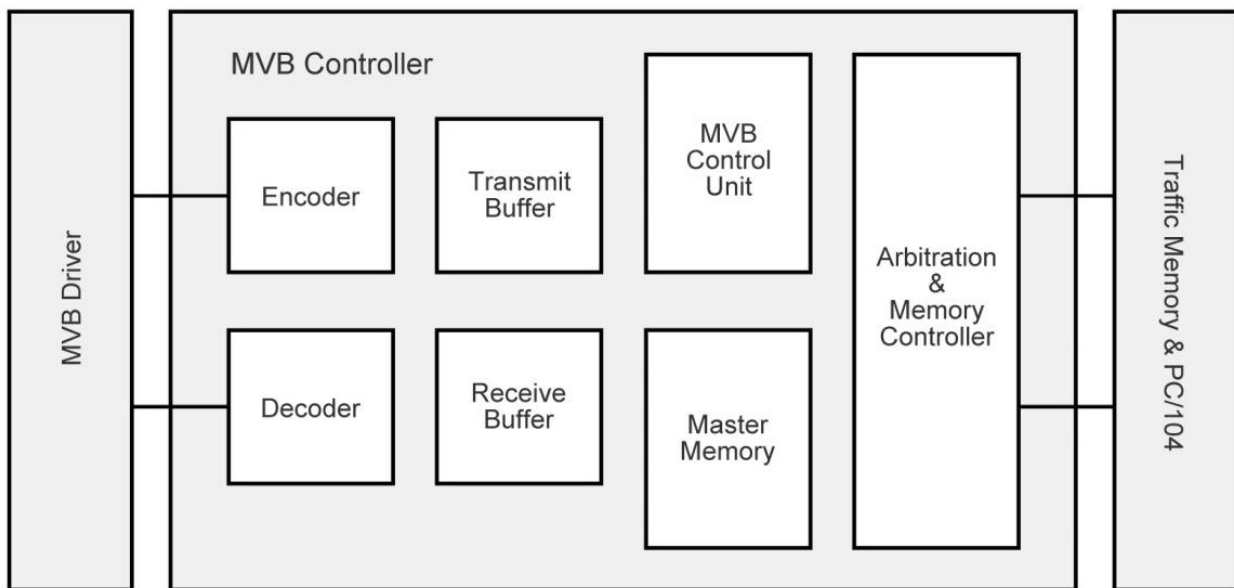

〈Figure 2-1. MVB Logic Structure〉

Item	Spec
Encoder/Decoder	Create MSD/SSD/ED, Data Encoding and Decoding, Calculate Check Sequence
Transmit Buffer	Data Buffer to transfer
Receive Buffer	Received Data Buffer
MVB Control Unit	Switchover, Mastership Transfer, Master/Slave transmission and reception
Master Memory	When Master function is executed, it is saved in Master List
Arbitration/Memory Controller	Interfacing between PC/104 and Master Memory and Traffic Memory

〈Figure 2-2. MVB Logic Spec〉

AM01S Series

3. MVB Interface

3-1. Pin Assignment for the ESD Connector

ESD(Electrical Short Distance) MVB connector should check the Option information of ordering information before ordering.

※ MVB Connector : Dsub (J2, J6) / Ejection (J1-B, J1-C)

Dsub	Ejection	Pin Name	Pin Description
1	1	A. Data P	Positive Wire of Line A
2	3	A. Data N	Negative Wire of Line A
3	5	NC	No Connected
4	7	B. Data P	Positive Wire of Line B
5	9	B. Data N	Negative Wire of Line B
6	2	A. Bus GND	Ground Line A
7	4	B. Bus GND	Ground Line B
8	6	A. Bus 5V	Positive Supply Line A
9	8	B. Bus 5V	Positive Supply Line B
Shield	10	Shield	Housing Shield

〈Figure 3-1. MVB Connector Spec〉

3. MVB Interface

3-2. MVB Connector Option

You can freely choose and order Connector Type according to MVB Board mounting structure. Please before placing an order, check the Option of Ordering Information.



〈Option A〉

Right Female/Male Dsub



〈Option G〉

Right Header with Long Ejection



〈Option H〉

Right Header with Short Ejection



〈Option K〉

Straight Top Socket

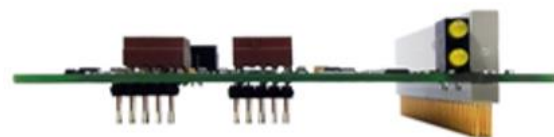

〈Option L〉

Straight Bottom Header

AM01S Series

4. PC/104 Interface

4-1. Pin Assignment for the PC/104 Connector

It complies with PC/104 standard and produces 8bit operation as basic specification. If you need 16bit operation, please check the Ordering Information Option.

Row A		A27	SA4	B21	IRQ7	C14	SD11
A1	IOCHK#	A28	SA3	B22	IRQ6	C15	SD12
A2	SD7	A29	SA2	B23	IRQ5	C16	SD13
A3	SD6	A30	SA1	B24	IRQ4	C17	SD14
A4	SD5	A31	SA0	B25	IRQ3	C18	SD15
A5	SD4	A32	GND	B26	NC(DACK2#)	C19	NC(KEY)
A6	SD3	Row B		B27	NC(TC)	Row D	
A7	SD2	B1	GND	B28	BLAE	D0	GND
A8	SD1	B2	RESETDRV	B29	+5V	D1	MEMCS16#
A9	SD0	B3	+5V	B30	NC(OSC)	D2	IOCS16#
A10	IOCHRDY	B4	IRQ9	B31	GND	D3	IRQ10
A11	AEN	B5	NC(-5V)	B32	GNC	D4	IRQ11
A12	SA19	B6	NC(DRQ2)	Row C		D5	IRQ12
A13	SA18	B7	NC(-12V)	C0	GND	D6	IRQ15
A14	SA17	B8	NC(SRDY#)	C1	NC(SBHE#)	D7	IRQ14
A15	SA16	B9	NC(+12V)	C2	LA23	D8	NC(DACK0#)
A16	SA15	B10	NC(KEY)	C3	LA22	D9	NC(DRQ0)
A17	SA14	B11	SMEMW#	C4	LA21	D10	NC(DACK5#)
A18	SA13	B12	SMEMR#	C5	LA20	D11	NC(DRQ5)
A19	SA12	B13	IOW#	C6	NC(LA19)	D12	NC(DACK6#)
A20	SA11	B14	IOR#	C7	NC(LA18)	D13	NC(DRQ6)
A21	SA10	B15	NC(DACK3#)	C8	NC(LA17)	D14	NC(DACK7#)
A22	SA9	B16	NC(DRQ3)	C9	MEMR#	D15	NC(DRQ7)
A23	SA8	B17	NC(DACK1#)	C10	MEMW#	D16	+5V
A24	SA7	B18	NC(DRQ1)	C11	SD8	D17	NC(MASTER#)
A25	SA6	B19	REFRESH#	C12	SD9	D18	GND
A26	SA5	B20	NC(BCLK)	C13	SD10	D19	GND

※ When the signal is Active Low, it is indicated by #

4. PC/104 Interface

4-2. PC/104 Connector Option

You can freely choose and order PC/104 Connector Type according to MVB Board mounting structure. Please check the option information of ordering information and place an order.

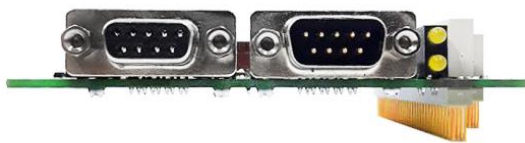

〈Option A〉

PC/104 Standard Press Fit 104pin

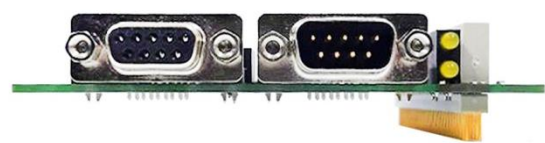

〈Option B〉

PC/104 Standard Press Fit 64pin



〈Option C〉

PC/104 Standard Top Socket 104pin

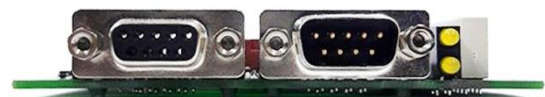

〈Option D〉

PC/104 Standard Top Socket 64pin



〈Option E〉

Standard Bottom Header 104pin

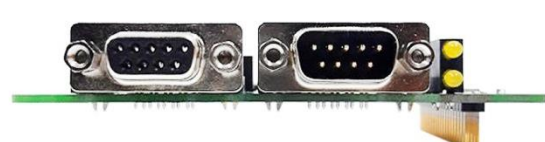

〈Option F〉

Standard Bottom Header 64pin

AM01S Series

5. Debug Interface

The debug Serial Interface uses a Serial 3.3V level signal and can identify Master and Slave Frame/Error Counter in line A and B.

Number	Pin Name	Property
1	RXD	3.3V Serial Receiver Data
2	TXD	3.3V Serial Transmitter Data
3	GND	Serial GND

6. Mechanical Data

6-1. Component Layout

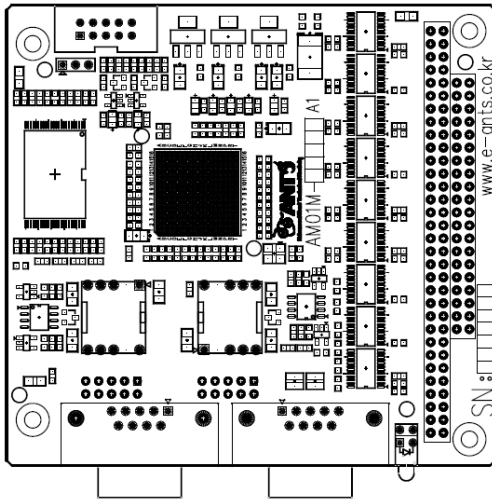

<Top Component Layout>

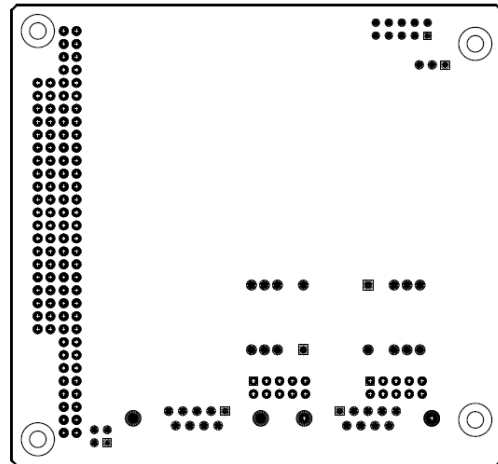

<Bottom Component Layout>

6-2. Dimensional Data

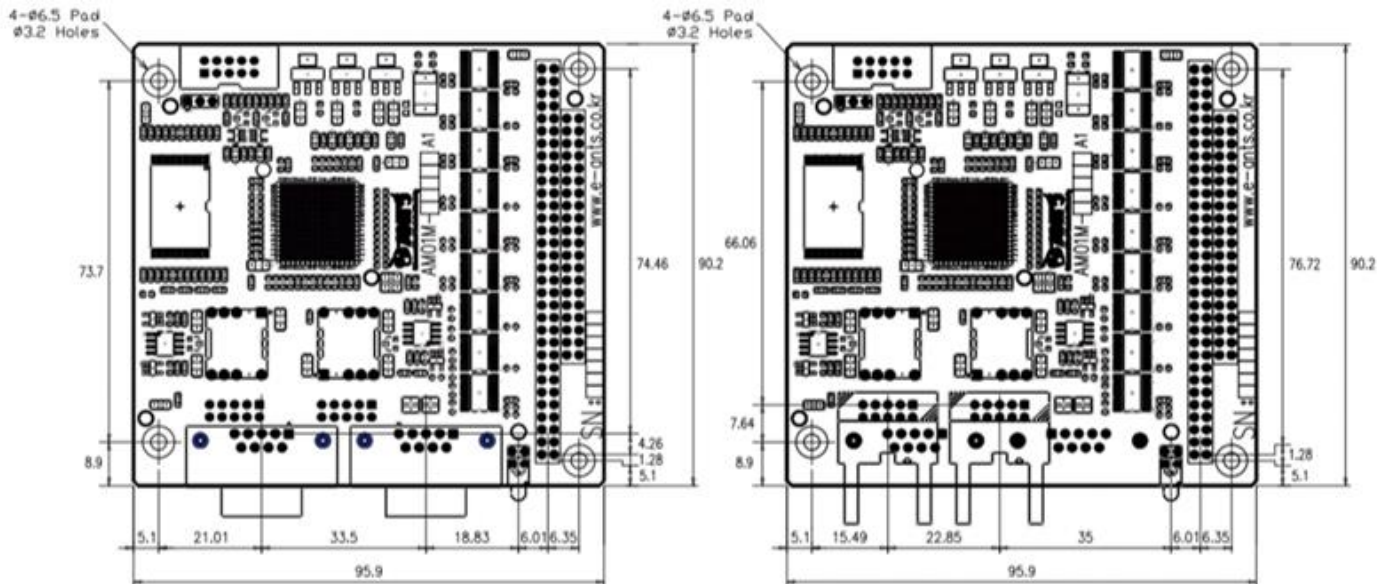

<MVB Dsub Type>

<MVB Ejection Type>

AM01S Series

6. Mechanical Data

The Debug Serial Interface uses a Serial 3.3V Level signal and can identify Master and Slave Frame/Error Counters in line A and B.

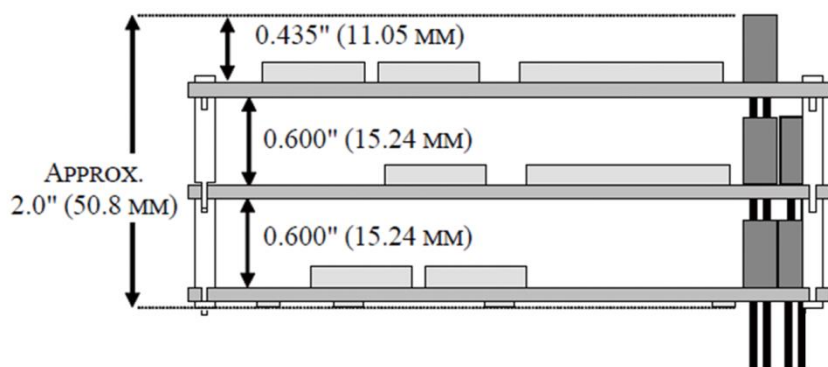

<Max Connection Data>

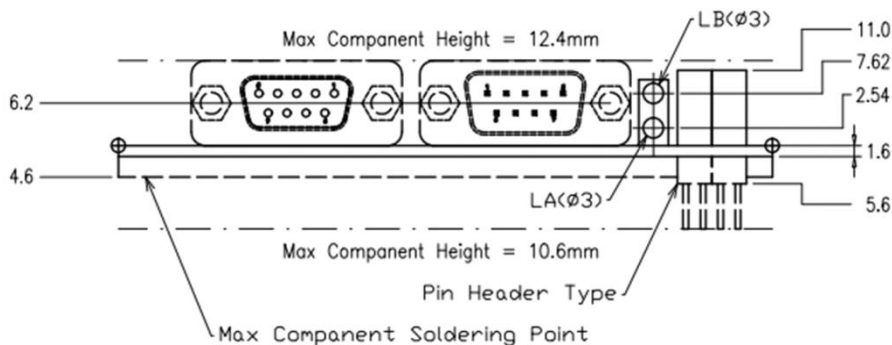

<PC/104 Module Stack Configuration>

7. Technical Note

7-1. State LED

Number	Pin Name	Property
D1	TXD	Debug Serial TX Flickering on transmission
D2	Master	Lights On when Master is set in Class 4
D3	RXD	Debug Flashing on receiving Serial RX
D4	Class	Class 1 to 3 Lamp off, Class 4 Lamp on
D5	FPGA	Flashing during FPGA operation
D6	Start	Lights On when Start is set
D7	Power	Lights On when power is on
D8	Line A/B	Lights On when occupying MVB Line A or B

7-2. PC/104 Timing Diagram

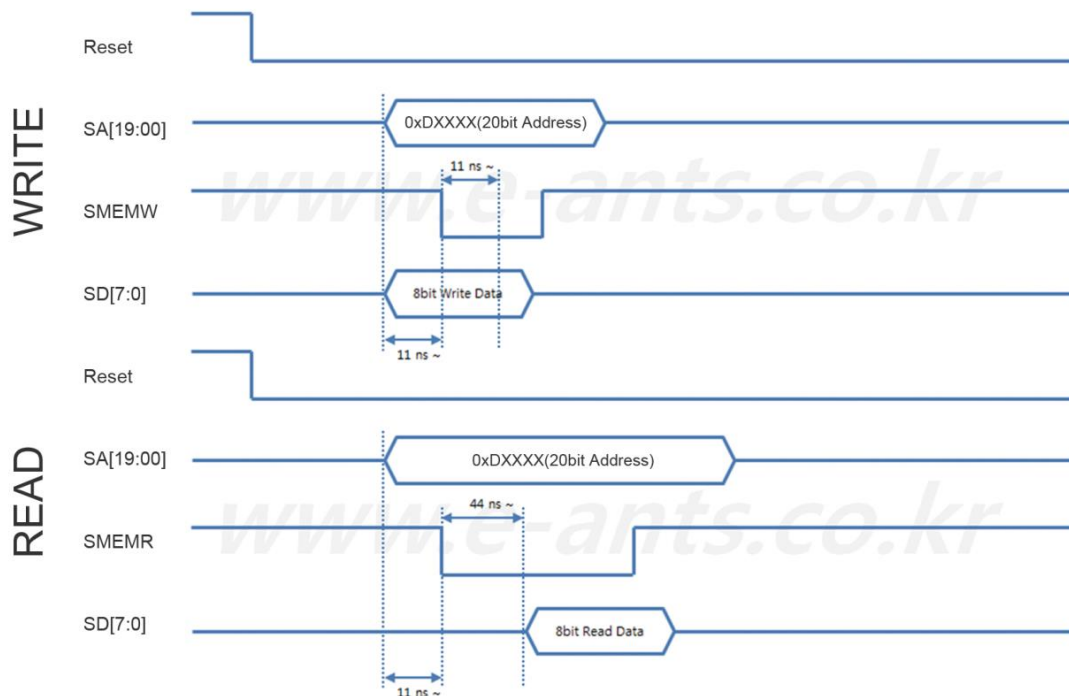

7-3. Power Up and Reset Sequence

It takes about 2 seconds to set up the FPGA and Traffic Memory at power-on and after can be used via PC/104 later.

AM01S Series

8. Standard and Certification

8-1. IEC 61375-3-1, IEC 61375-3-2 Standard Reference

8-2. PC/104 Specification Reference

8-3. Environment Test Standard Reference

Data/No	Subject
IEC 61373:2010	Railway applications–Rolling stock equipment–Shock and Vibration tests(Category 1/Class B)
IEC 60571:2012	Railway applications–Electronic equipment used on Rolling stock
IEC 60068-2-1:2007	Environmental testing–Part 2-1: Tests A: Cold, Test Ad
IEC 60068-2-2:2007	Environmental testing–Part 2-2: Tests B: Dry heat
IEC 60068-2-14:2009	Environmental testing–Part 2-14: Tests N: Change of Temperature
IEC 60068-2-30:2005	Environmental testing–Part 2-30: Tests Db: Damp heat(12h+12h Cycle)
IEC 61000-4-5:2014	Electromagnetic compatibility(EMC)–Part 4-5: Testing and Measurement techniques–Surge immunity test
IEC 61000-4-2:2008	Electromagnetic compatibility(EMC)–Part 4-2: Testing and Measurement techniques–Electrostatic discharge immunity test
IEC 61000-4-4:2012	Electromagnetic compatibility(EMC)–Part 4-4: Testing and Measurement techniques–Electrical fast transient/Burst immunity test
IEC 61000-4-3:2006+A2:2010	Electromagnetic compatibility(EMC)–Part 4-3: Testing and Measurement techniques–Radiated, Radio-Frequency, Electromagnetic field immunity test
IEC 61000-4-6:2013	Electromagnetic compatibility(EMC)–Part 4-6: Testing and Measurement techniques–Immunity to Conducted disturbances, Induced by Radio-Frequency fields
CISPR 11:2015	Industrial, Scientific and Medical equipment–Radio-Frequency disturbance characteristics–Limits and Methods of Measurement

8. Standard and Certification

8-4. MVB Conformance Test

We have passed the Bombardier TCN Level 1 MVB Conformance Test to verify the reliability of our MVB products.

Legal owner: RoQ	Responsible Unit: TTT	Document type: Test Report	BOMBARDIER	
Prepared: 2017-10-11	T. Flügel (s.o.f.)	TCMS Level 1 MVB Conformance Test	Document state: APPROVED	
Checked: ---	---	ANTS Co.,Ltd ESD Ethernet/USB Controller	3EGM007200D4079	
Approved: 2017-10-11	G. Hans (s.o.f.)	File name: 3EGM007200D4079 TCMS Level 1 MVB ConTest_ANTS_ESD Ethernet_USB Controller	Revision: ---	Language: en Page: 1 / 20

Test Object: ANTS Co.,Ltd ESD Ethernet/USB Controller
Identification No: S/N: AP-MVB-P002-A0 Rev.: A0
Test Date: 2017-08-31 and 2017-09-29

Participants

Function	Department	Name
Tester	TTT	Thorsten Flügel

Kind of Test: Interoperability test
Test Sequence: first test
 re-examination to:

Related Standards and Guidelines: TCN Standard IEC61375-3-1 2012-06

Test Specifications and Test Instructions: 3EGM007200D1408 rev. F, TCMS Level 1 MVB Conformance Test

Test Certificate:

<input checked="" type="checkbox"/>	Decision	Next Steps
<input checked="" type="checkbox"/>	Test passed	
<input type="checkbox"/>	Test passed with restrictions	see chapter 4, Overview of results
<input type="checkbox"/>	Test failed	

Remarks: See chapter 4 overview of results.

Template-id: 3EGM027494D0045 Rev. _9 June 2001
 We reserve all rights in this document and in the information contained therein.
 Reproduction, use or disclosure to third parties without express authority is strictly forbidden.
 © Bombardier Transportation GmbH 2017

AM01S Series

9. Ordering Information

Please refer to Ordering Information when ordering the product.

ORDERING INFORMATION

AM01S _____ 1 Series

Class

- 1 – Class 1 (Process Data)
- 2 – Class 2 (Message Data)
- 3 – Class 3 (Message Data)
- 4 – Class 4 (Bus Administration, Master)

MVB Connector Option

- A – Right Female/Male Dsub
- G – Right Header with Long Ejection
- H – Right Header with Short Ejection
- K – Straight Top Socket
- L – Straight Bottom Header

Mount Connector Option

- A – PC/104 Standard Press Fit 104pin
- B – PC/104 Standard Press Fit 64pin
- C – PC/104 Standard Top Socket 104pin
- D – PC/104 Standard Top Socket 64pin
- E – PC/104 Standard Bot Header 104pin
- F – PC/104 Standard Bot Header 64pin

Dsub Screw Option

- 3 – M 3 Screw Locks
- 4 – UNC 4-40 Screw Locks
- 0 – No Assembly